

CONNECTION



VBG GROUP

NEWSLETTER FROM VBG GROUP SALES LTD

1/2009

On-site VBG servicing key to success

A VBG GROUP SALES LTD customer has built up a successful business fitting and servicing VBG coupling equipment around the south western area of the UK. Read more about how they did it on page 4!

Updated heavyweight

For really big, heavy and long distance freight you need equipment that you can rely on. A new generation of couplings does the job even better – see page 3!

ALL-IN-ONE SUCCESS!

VBG's much awaited Multi Function Coupling concept finally had its public premiere at the Elmia and IAA shows. We have never seen such a high degree of interest – read more inside!



There were large crowds round the MFC vehicle on display at IAA.

Support from VBG foundation advances asthma research

Nalle Lindholm, retired Gothenburg physician, makes sure that the funds from VBG's owners' foundation get used in the best possible way. Every year large sums of money from the foundation's dividends are allocated to research into asthma and allergies. Two professorships at Sahlgrenska

University Hospital have been financed with contributions from the foundation, which was established as a result of a large donation from VBG's founder, Herman Krefting – who also suffered from asthma for many years. Read more on the next page!

Two professorships supported by VBG

In the early 80s, a doctor at the Sahlgrenska hospital in Gothenburg had an asthma patient from Vänersborg. The doctor was Nalle Lindholm, who for many years had been head of the clinic and associate professor in the care of asthma and allergies. The patient was VBG's founder Herman Krefting, who had been suffering from asthma since nearly all his life.

Herman and his doctor often discussed how care for asthma and allergy patients could be improved. When he began planning for his retirement he chose to donate a large part of his fortune to three foundations. One of these was the Herman Krefting Foundation for Allergy and Asthma Research, which received VBG shares to administrate for the support of the clinic's research activities at the Sahlgrenska University Hospital's unit for adult allergies.

Over £ 4,000,000 and two professorships
Herman's doctor became the medical advisor for the foundation and since the mid 80s has allocated over £ 4,000,000 to research projects – initially relatively modest amounts for a large number of small projects.

Scholarships from the hand of Queen Silvia
"After a few years we decided to consolidate the input. We issued a number of scholarships that enabled competent doctors to take time off from their daily work for a few months, to concentrate on their research. During the Allergy Year in 1995 we had the honour of having Queen Silvia award the scholarships," explains Nalle Lindholm, and adds:
"Eventually we realised that we would get the best out of the contributions by building up a permanent platform for competent research at an academic level. The foundation agreed, and with the help of the dividends we were able to appoint two professorships. The long-term commitment of the foundation en-

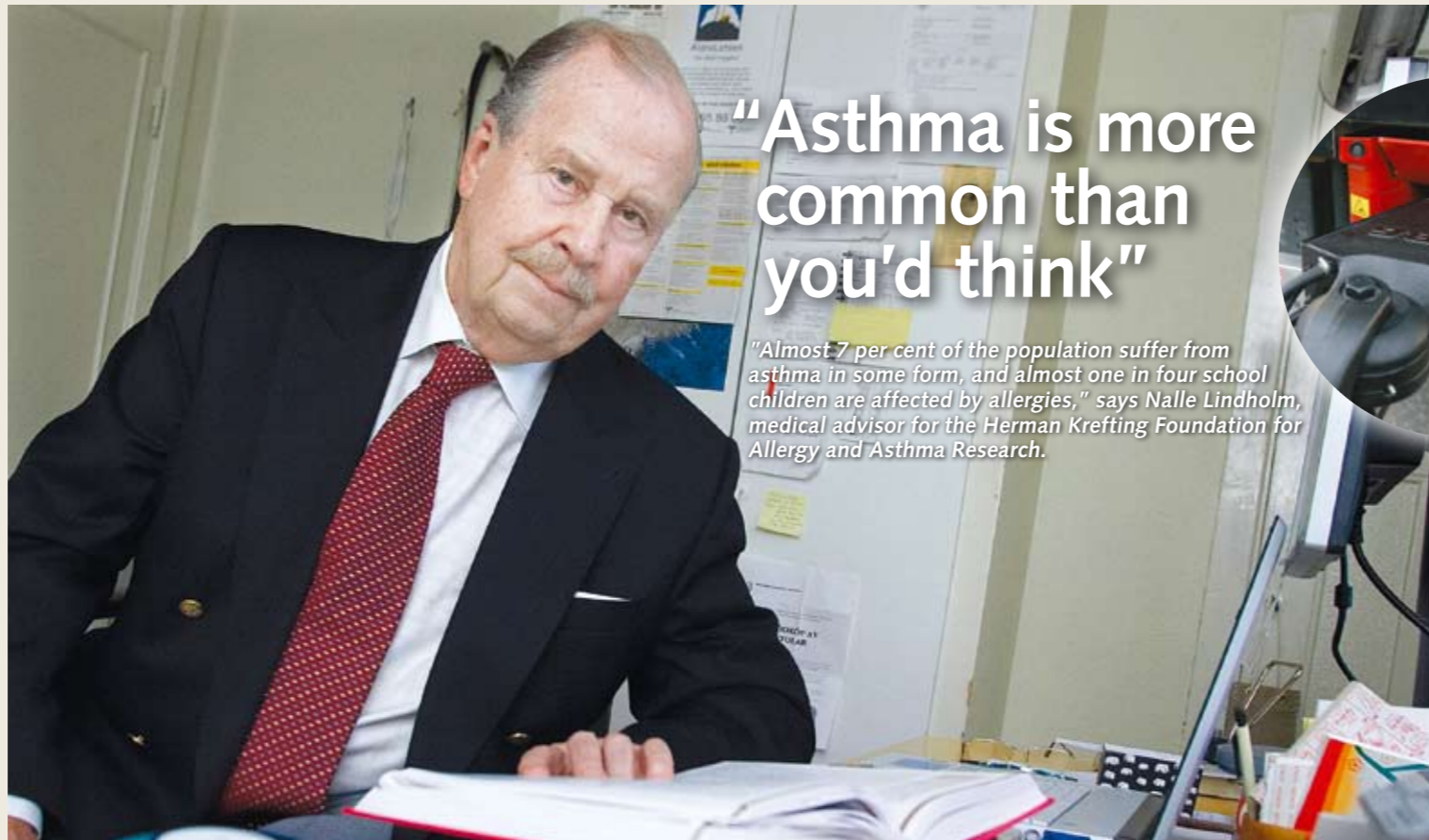

"Asthma is more common than you'd think"

"Almost 7 per cent of the population suffer from asthma in some form, and almost one in four school children are affected by allergies," says Nalle Lindholm, medical advisor for the Herman Krefting Foundation for Allergy and Asthma Research.

sure a well-needed continuity in the research," says Nalle, who is now retired, but still engaged in the foundation.

One in four children are allergy sufferers
Has research into asthma taken any decisive steps forward as a result of this support? "We certainly hope so," says Nalle – "serious research benefits all of us sooner or later in one form or other. Asthma is a much more common disease than many people believe. 6–7 per cent of the population suffer from some form of asthma, and around one in four school children will soon be affected by allergies. So it really is important to make some progress."

When he first began in this field in the late 50s, cortisone was used in tablet form for the treatment of asthma. It had an extraordinary effect, but unfortunately also bad side-effects. The first inhalers with cortisone in spray form came out in the 60s, and they were first tested here at Sahlgrenska. It was a major step towards better control of asthma.

Not the same handicap anymore
"Asthma is a disease that must be given serious attention not to get worse. By now we have learned how to treat asthma, so that it no longer is anywhere near the handicap it once was," explains Nalle Lindholm.
Jan Lötval – once himself a scholarship recipient

MFC – A CROWD MAGNET



Interest in the new MFC coupling was enormous at the premier at the Elmia Show, says Thomas Bergenklev, Marketing Manager at VBG GROUP TRUCK EQUIPMENT AB. The demo vehicle was in operation almost nonstop – and there were huge crowds around the long-awaited comfort coupling. The MFC was also a major attraction at IAA (see page 1). Keep a look out for the next issue, when we will find out how the first buyers feel about their MFCs!

57 years with 57 mm

At the Elmia Show, VBG also took the opportunity to celebrate an unusual anniversary – 57 years with 57 mm couplings! Börje Bappelsin*, the totally unpredictable comic, entertained at the party. When he's around, anything can happen – and it did!

*His name would translate into "Ben Borange", or something like it.

Show calendar '09

- 31 March–2 April Carrosserie Vakdagen, Hardenberg, NL
- 6–9 May Logistikka Kuljetus, Helsingfors, FI
- 7–10 May Transport show at Gardermoen, NO
- 23–24 May Vestfyn Trækker, Ejby, DK
- 14–15 August Mittia, Ljusdal, SE
- 1–3 September Carrosserie Vakdagen, Gorinchem, NL

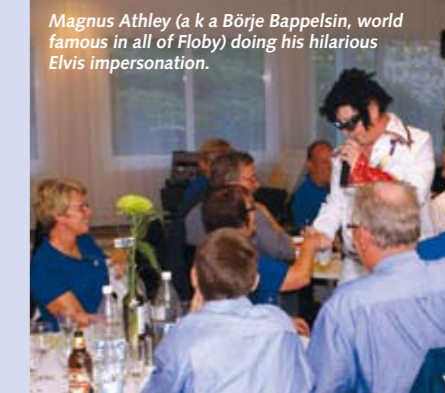

Magnus Athley (a.k.a. Börje Bappelsin, world famous in all of Floby) doing his hilarious Elvis impersonation.

Asthma – how does it work?

There are several types of asthma, of which about one third are considered to be allergy-related. Asthma is caused by inflammation and swelling of the respiratory tracts, which hinders breathing. This causes the formation of mucus, and can lead to cramps which worsens the symptoms.

The disease can remain dormant for long periods, but may suddenly become aggravated and triggered by allergies, cold weather or exertion.

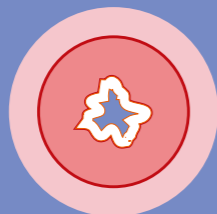

Airwaves with swollen mucus membranes

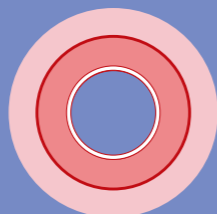

Normal airways

Attacks can come unexpectedly and may even be life-threatening, although nowadays asthma can usually be kept under control. An asthma patient must be very careful with their medication and must not neglect their way of life, since the untreated complaint can lead to chronic problems. Good contact, preferably with the same doctor and nurse, simplifies the care of asthma patients.

7310 D – new heavyweight coupling



Our new extra heavy duty coupling is called VBG 7310 D and is based on our experiences from the VBG 3000, which it is now replacing. The new coupling incorporates an even stronger attachment and is intended for trailers with articulated drawbars. The attachment with ten bolts fitted to the drawbeam means that the coupling can absorb extremely high forces.

TECHNICAL DATA

Part number	09-073100
Performance values	D: 310kN
Hole pattern, drawbeam	10-hole pattern
Intended for eye size	Ø 57 mm
Dead weight	92 kg
EU coupling class	S
EU approval no.	e4*94/20*6336*01



Business partners Robin Turner and Peter Taylor in Bruton are proud to display their VBG expertise on their new Fiat van.

First class VBG service by Turner's

Turner's, a company based in Bruton, a small town in Somerset, is 100% committed to VBG. This fact is proudly displayed on their new service van, which is fully equipped with service tools and a good stock of VBG spare parts.

Their main focus is on sales, repairs and servicing of VBG drawbar equipment. In the early days they mainly did chassis modifications and trailer building, but seeing an opening in the market they started concentrating on service contracts, installations in their own workshop, and most recently on-site fitting services for bodybuilders within a hundred mile radius of their premises.

They still manufacture trailers when time permits, but feel their future lies with the sales, service and installation of VBG equipment. Many customers

now see the benefit of taking out a contract to cover the inspection and servicing of their drawbar equipment, not only to satisfy the authorities but also to ensure that downtime is kept to a minimum, and that the truck and trailer are always safe to use. They have created a large customer base built on trust and the benefits of bringing service facilities to the customer's premises. Their portfolio includes blue-chip companies – but the bulk of their customers have only small fleets, and to them customer service really matters.

Robin Turner reckons the key to their success is being able to offer high-quality services to their customers, maintaining an adequate stock of couplings, beams, endplates and other spare parts – and of course, the support of the VBG team at Warrington!

Stricter rules for underrun protection

The EU directive 70/221/EEC on rear underrun protection for motor vehicles and trailers has been changed to adapt the directive to technical developments. One important difference is higher requirements for impact resistance – underrun protection must now withstand a force corresponding to 25 per cent of the total weight of the vehicle, or a maximum of 50 kN. As of March 2010 all new components or vehicles must comply with the directive. On vehicles with tail lifts the underrun protection must be installed so that there is enough space for the controls. Most of the previous exemptions from the regulations have been retained. Because of this VBG has produced new underrun protection, and the existing endplate kits have been modified to suit the new programme.

The new underrun protection with its substantially sturdier cross-section meets higher safety standards.

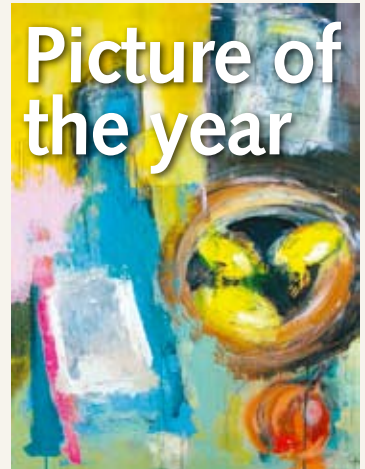
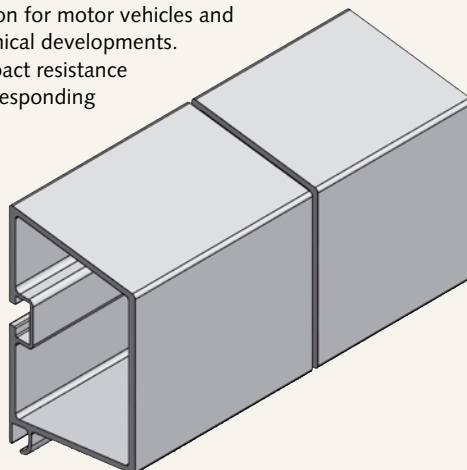

The young Danish artist *Suzanne Cecilie Jagd* has painted VBG's Picture of the Year, the eleventh in succession. She works in oils and acrylics, often with contrasting colours, structures and abstract forms. Her "Still Life in Yellow" is available as a reproduction in a signed, limited edition. To receive one free of charge, please contact us at vbgltd.co.uk – but hurry, before they all go!



Bridges from all over the world!

The theme for the VBG calendar for 2009 is "Connections Worldwide", with beautiful bridges from most continents – both large and small. If you are lucky there might be a few copies left to give away – mail us at vbgltd.co.uk and check!