

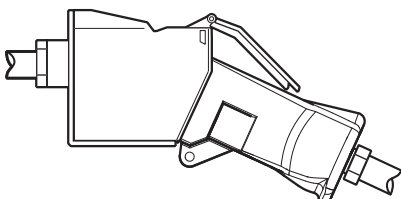

Power plug 14 /17 SAL

Mounting Instructions

2010-10-06 38-134105d

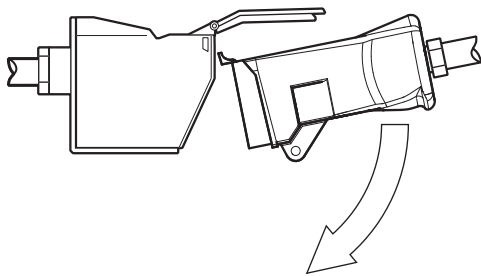
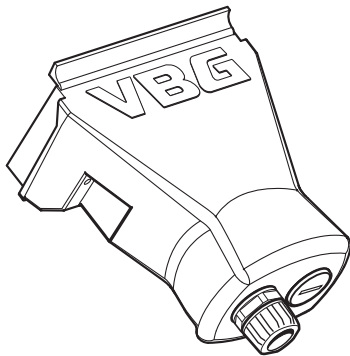
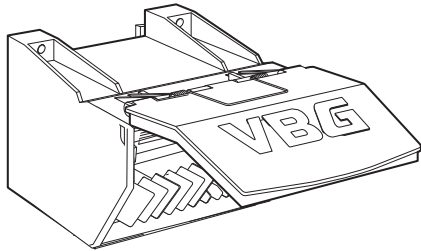

Description

The contact consists of two parts:

The vehicle section - contact box

Trailer section - socket

The socket and contact box have conduit entries dimensioned for cables $\varnothing 10.5$ mm - $\varnothing 17.5$ mm.

The inserts are provided with gaskets and the socket is provided with a lock hook.

Identify all parts before assembly. All assembly and service work must be performed carefully and in a professional manner.

Follow the instructions.

Always observe the vehicle manufacturer's instructions for electrical installation on the vehicle.

Leave all instructions and directions in the vehicle for the customer as a reference for future service and maintenance.

General

- Cable dimension should always be chosen taking power consumption into consideration. When dimensioning, keep in mind any extra equipment that may be fitted at a later date. Maximum allowed amperage for VBG's trailer connections is limited by the earthing capacity, i.e. maximum 25 A.

- Weekly maintenance of the contact surfaces involves cleaning and corrosion protection using VBG Electro Oil.

- In particularly severe operating conditions, the contact box should be equipped with a heating coil, part number 28-029900.

- *Do not connect a 14-terminal socket to a 17-terminal contact box or vice versa. Risk of short circuits.*

14-terminal White insert

17-terminal Yellow insert

In the 17-terminal socket, the space at terminal 8 is blocked off to avoid confusion.

Fitting the socket

1. Fit an appropriate bracket on the vehicle.

2. Slip the conduit entries onto the cable. The protective cover should be dimension NC 20 (17 mm outside diameter).

28-035900: Slip the conduit entries onto the cable. The protective cover should be dimension NW 26 (26 mm outside diameter).

3. If both conduit entries are not to be used, fit a plug, washer and gasket in the unused one

4. Lock the cover in the open position.

5. Remove the insert and pull each cable through its respective entry point. Pull it out as much as far as necessary to make working on the connections easier.

6. Strip the cable casing back about 60 mm.

7. Check and label the wires by function.

8. Strip the wires about 5 mm. Fit cable terminals with the recommended dimensions.

9. Connect the cables to the flat connector blades in the insert as per the wiring plan. Spray a layer of VBG Electro Oil onto the cable terminals and connector blades to prevent corrosion.

10. Place the insert in the box and fix it using two screws. Be careful not to damage the gasket.

N.B. The upper edge of the insert should be located inside the support heel in the upper edge of the box (10b). Close the cover.

11. Adjust the cable at each conduit entry point without exerting pressure on the cable.

12. Insert and tighten the conduit entry with moderate force so that it seals.

13. Fit the socket onto the brackets with three screws, lock washers and nuts. The contact box should be seated horizontally and with the label upwards.

- Fit the electrical heating coil (where applicable) between the parking light and earth in the contact box.

Wiring plan

Ter. 14-terminal (white)	17-terminal (yellow)
1 Earth	Earth
2 Left Flashers	Left Flashers
3 Right Flashers	Right Flashers
4 Brake Lights	Brake Lights
5 Left Tail Lights	Left Tail Lights
6 Right Tail Lights	R Tail Lights B Aux
7 A Tail Light B Tail Fog Light	A Tail Light B Tail Fog Light
8 A Aux B Aux	A Aux
9 Aux	A Aux B Aux
10 Aux	A Aux B Aux
11 Aux	A Aux B Aux
12 Charging Current	Charging Current

- Terminals 1 and 12 require larger cable terminals (9.5 mm). The cable dimension shall always be chosen taking power consumption into consideration. When dimensioning, keep in mind any extra equipment that may be fitted at a later date. Maximum allowed amperage for VBG's trailer connections is limited by the earthing capacity, i.e. maximum 25 A.

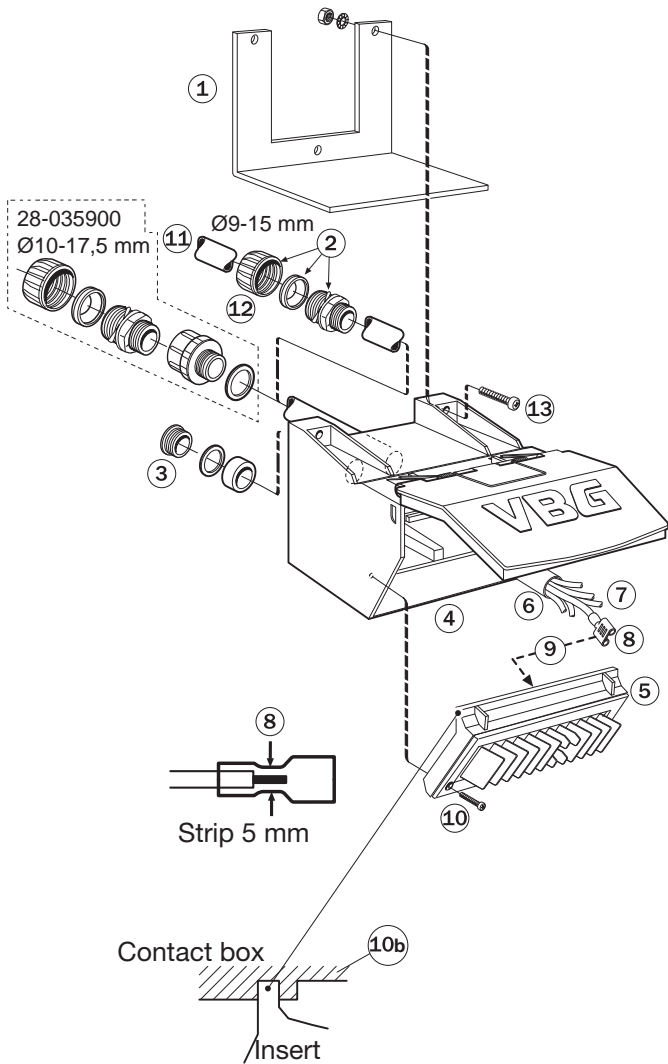

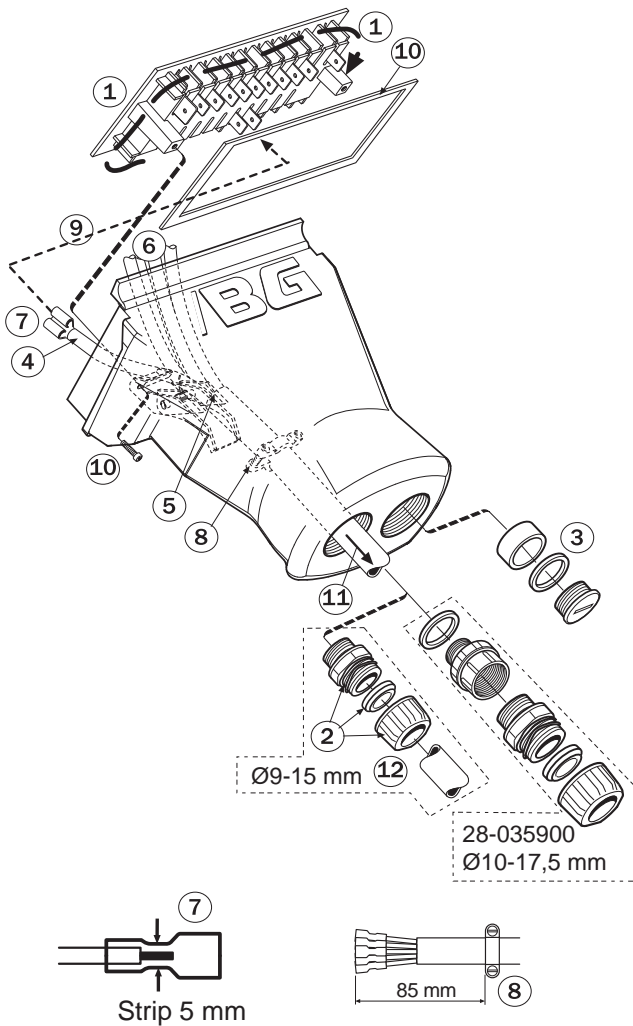

Fitting the plug

1. Remove the insert. To prevent the terminals from falling out, wind a bit of electrical tape around the insert. Check that the gasket still is attached to the insert.
2. Slip the conduit entries onto the cable. The protective cover should be dimension NC 20 (17 mm outside diameter).
28-035900: Slip the conduit entries onto the cable. The protective cover should be dimension NW 26 (26 mm outside diameter).
3. If both conduit entries are not to be used, fit a plug, washer and gasket in the unused one.
4. Pull each cable through its respective entry point. Pull it out as much as far as necessary to make working on the connections easier.
5. Strip the cable casing back about 60 mm.
6. Check and label the wires by function.
7. Strip the wires about 5 mm. Fit cable terminals with the recommended dimensions.
8. Set the cable clamp 85 mm from the cable terminals and tighten the screws until it is fixed on the cable.
9. Connect the wires to the blade connectors in the cartridge as per the wiring plan. Spray a layer of VBG Electro Oil onto the cable shoes and connector blades to prevent corrosion.
10. Place the insert in the box and fix it using two screws. Be careful not to damage the gasket.
11. Check by pulling the cable that the hose clamp is properly mounted.
12. Insert and tighten the conduit entry with moderate force so that it seals.
 - A parking bracket for the plug, for use when the trailer is uncoupled, can be fitted on the drawbar, part no. 28-030100. See figure.

Wiring plan

Ter. 14-terminal (white)	17-terminal (yellow)
1 Earth	Earth
2 Left Flashers	Left Flashers
3 Right Flashers	Right Flashers
4 Brake Lights	Brake Lights
5 Left Tail Lights	Left Tail Lights
6 Right Tail Lights	R Tail Lights B Aux
7 A Tail Light B Tail Fog Light	A Tail Light B Tail Fog Light
8 A Aux B Aux	A Aux
9 Aux	A Aux B Aux
10 Aux	A Aux B Aux
11 Aux	A Aux B Aux
12 Charging Current	Charging Current

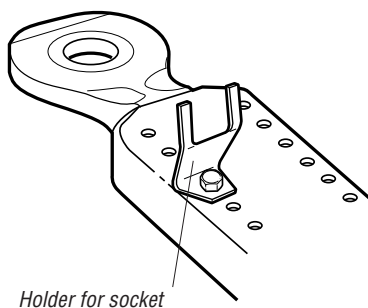

- Terminals 1 and 12 require larger cable terminals (9.5 mm). The cable dimension shall always be chosen taking power consumption into consideration. When dimensioning, keep in mind any extra equipment that may be fitted at a later date. Maximum allowed amperage for VBG's trailer connections is limited by the earthing capacity, i.e. maximum 25 A.

VBG GROUP TRUCK EQUIPMENT AB reserve the right to amend or alter specifications at their discretion.



VBG GROUP TRUCK EQUIPMENT AB

Herman Kreftings gata 4
Box 1216
SE-462 28 VÄNERSBORG
Tel +46 521 27 77 00
E-mail info@vbg.se
www.vbg.se